

| | |
|--------------------------|--------------------------|
| Name: _____ | Date: _____ Event: _____ |
| City: _____ State: _____ | Track: _____ |

Track Indoor Tight Smooth Hard Packed Blue Groove Wet Low Bite High Bite
 Conditions Outdoor Open Rough Loose/Loamy Dry Dusty Med Bite Other _____

Front Suspension

Toe: _____
 Ride Height: _____
 Camber: _____
 Caster: _____
 Spindle Height: High Low
 Wheel Hex: _____
 Sway Bar: _____
 Piston/Oil: _____
 Shock Type: Bladder Emulsion
 Spring: _____
 Limiter/Droop: _____
 Overall Shock Length: _____
 Steering Ackerman: _____
 Bump Steer: _____
 Camber Link: _____
 Shock Location: _____
 Receiver Battery Type: _____

Differentials

Front: Standard Smart
 Spring Wire Dia. _____
 Qty of Springs: _____
 Ramp Plate: _____
 Grease: _____
 Diff Fluid: _____

Center: Standard Smart
 Spring Wire Dia.: _____
 Qty of Springs: _____
 Ramp Plate: _____
 Grease: _____
 Diff Fluid: _____

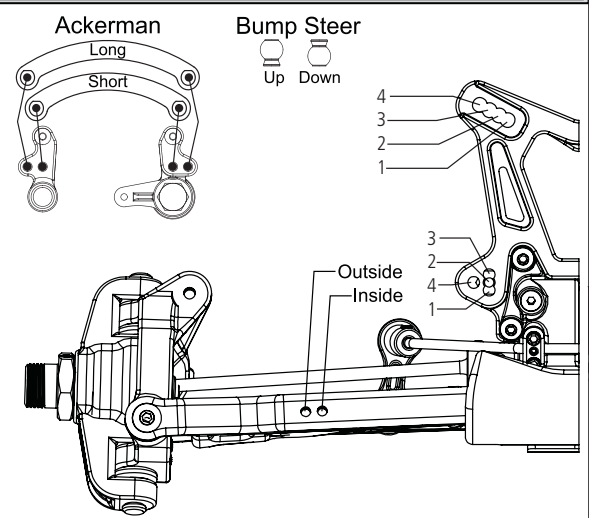

Notes: _____

Rear Suspension

Roll Center: HRC LRC
 Toe: _____
 Anti-Squat: _____
 Ride Height: _____
 Camber: _____
 Rear Hub Spacing: _____
 Wheel Hex: _____
 Sway Bar: _____
 Piston/Oil: _____
 Shock Type: Bladder Emulsion
 Spring: _____
 Limiter/Droop: _____
 Overall Shock Length: _____
 Camber Link: _____
 Shock Position: _____
 Rear Diff Fluid: _____

Wing Setup

Wing Type: 2.0 3.0
 Wing Spacer: .250 .500
 Wicker Bill: .250 .350

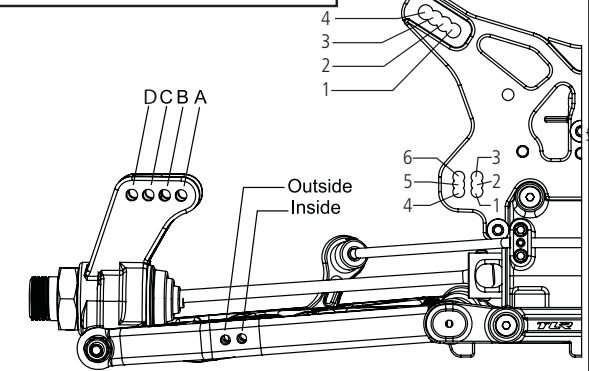

Notes: _____

Engine

Engine: _____ Fuel: _____
 Glow Plug: _____ Head Clearance _____
 Pipe/Header: _____ Gearing: _____

Clutch Clutch Shoes and Springs Info

Tires

| Type | Compound | Insert |
|--------------|----------|--------|
| Front: _____ | _____ | _____ |
| Rear: _____ | _____ | _____ |
| Notes: _____ | | |
| _____ | | |